

General information

According to 94/9/EC, a device that is to be used in an environment at risk of explosion may only be brought into the market if it satisfies the standards specified in the norm.

Compared with the previous directives, it must be noted that the specification refers not only to electrical but also to mechanical equipment (e.g. cylinders).

Devices are divided into categories and groups to accurately define the conditions of use. This definition is marked on the device and may appear as follows:

Example:

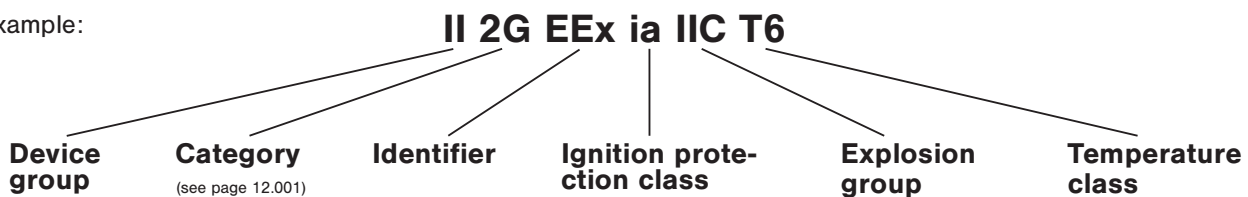

Device group

There are 2 groups of devices.

Devices of Group I, Category M are for use in underground mines and their above ground equipment, which are at risk from firedamp and/or inflammable dusts. (This is not given further coverage in this document).

All other areas at risk of explosion are combined in Device Group II.

Identifier

EEx defines that this is an electrical device.

Ignition protection class

This defines which measures are used to ensure explosion protection.

The following ignition protection classes are used by AIRTEC:

m = Encapsulation, **ia** = Intrinsic safety, **c** = Safe by design

Other ignition protection classes are defined in EN 50014: 1997. The abbreviations are currently under review discussion.

It should be noted that devices in ignition protection class ia may only be supplied from circuits that are certified to be intrinsically safe.

Explosion group

Device group II is sub-divided into Explosion Groups A, B or C.

This classification is dependent on the typical material properties of the gases and vapors that occur.

The hazard level of materials increases from Explosion Group IIA to IIC. The requirements for the devices increase accordingly. If a device is approved for IIC, it can be used for all other explosion groups. Alternatively, the chemical formula or the name of the material can be stated here.

Temperature class

It must be ensured that the ignition temperature of an inflammable material is not reached during operation. For this purpose, the maximum surface temperature of a device must be less than the minimum ignition temperature. For this reason, the maximum surface temperature of equipment for use with inflammable gases, vapors or mists is specified in temperature classes. For dusty environments, the maximum surface temperature is specified in °C.

Temperature class	Maximum permissible surface temperature of the equipment (°C)
T1	450
T2	300
T3	200
T4	135
T5	100
T6	85

General information

Category

The categories define which zones the devices may be used in. The classification states how frequently and in what concentration the ignitable mixture occurs. Furthermore, differentiation is made as to whether the hazard is due to gases, vapors and mists or due to dust.

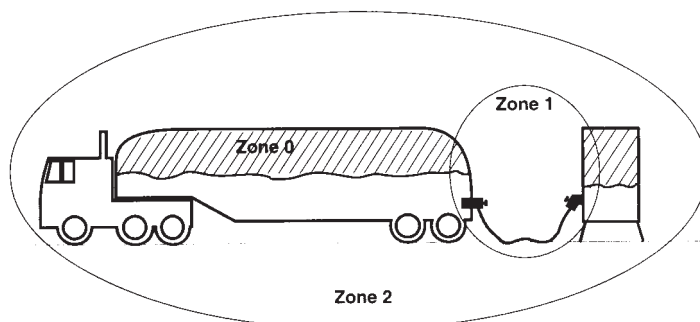

Example of zone classification in gas Ex area.

Category 1

For devices, which guarantee a **very high level** of safety.
Intended for the case where an atmosphere at risk of explosion is to be expected frequently or continuously.
Devices in this category can also be used in Category 2 and 3.

Inflammable gases, vapors or mists

Zone 0 equivalent to Category 1G

Area in which an atmosphere at risk of explosion as a mixture of air and inflammable gases, vapors or mists is continuously or frequently present or present for long periods.

Inflammable dusts

Zone 20 equivalent to Category 1D

Area in which an atmosphere at risk of explosion in the form of a cloud of inflammable dust contained in the air is continuously or frequently present or present for long periods.

Category 2

For devices, which guarantee a **high level** of safety.
Intended for the case where an atmosphere at risk of explosion is to be expected.
Devices in this category can also be used in Category 3.

Inflammable gases, vapors or mists

Zone 1 equivalent to Category 2G

Area in which an atmosphere at risk of explosion as a mixture of air and inflammable gases, vapors or mists can form occasionally during normal operation.

Inflammable dusts

Zone 21 equivalent to Category 2D

Area in which an atmosphere at risk of explosion in the form of a cloud of inflammable dust contained in the air can form occasionally during normal operation.

Category 3

For devices, which guarantee a **normal level** of safety.
Intended for the case where an atmosphere at risk of explosion is to be expected rather infrequently and, if so, for only short periods.

Inflammable gases, vapors or mists

Zone 2 equivalent to Category 3G

Area in which an atmosphere at risk of explosion as a mixture of air and inflammable gases, vapors or mists does not normally occur at all or only for short periods during normal operation.

Inflammable dusts

Zone 22 equivalent to Category 3D

Area in which an atmosphere at risk of explosion in the form of a cloud of inflammable dust contained in the air does not normally occur at all or only for short periods during normal operation.

The following AIRTEC products are available in explosion-proof design for Device Group II in accordance with 94/9/EC.

The following list is intended to provide an overview. Attention must be paid to the Operating Instructions and Declaration of Conformity before commissioning. These can be provided on request.

Electrically operated valves

Series	Functions	Classification	Special features	Catalogue page
MS-18	310	II 2GD c T5 T 100° C (II 3GD nA T5 T95 °C on request)	Valves are equipped with special actuators. Dimensional changes and technical data can be seen in the following pages. $T_{\text{Medium}} - 10^{\circ} \text{ C} \dots + 50^{\circ} \text{ C}$ $T_{\text{amb}} - 10^{\circ} \text{ C} \dots + 50^{\circ} \text{ C}$	4.040
M-04	310, 311, 320, 510, 511, 520, 530, 533, 534			4.080
M-05	310, 311, 320, 510, 511, 520, 530, 533, 534			4.110
ME-05	311, 320, 511, 520			4.110
MO-05	311			4.110
M-07	310, 311, 320, 510, 511, 520, 530, 533, 534			4.150
MO-07	311			4.150
ME-07	311, 320, 520			4.150
MG-07	510, 520, 530, 533			-
MN-06	310, 311, 320, 510, 511, 520, 530, 533			5.020
M-06	310, 311, 511			-
M-22	310, 510, 511, 520, 530, 533			4.180
KN-05	310, 311, 510, 520, 530, 533, 534			5.040
KM-09	510, 520, 530, 533, 534			4.120
KM-10	510, 520, 530, 533, 534			4.160
KME-10	520, 530			-
MI-01	510, 511, 520, 530, 533			5.060
MI-02	510, 520, 530, 533			5.080
MI-03	510, 520, 530, 533			5.100

Pneumatically operated valves

Series	Functions	Classification	Special features	Example order number	Catalogue page
P-04	311, 511, 530, 533, 534	II 2GD c T5 T 100° C	Compressed air in accordance with ISO 8573-1:2001 Class 74- $T_{\text{Medium}} - 10^{\circ} \text{ C} \dots + 50^{\circ} \text{ C}$ $T_{\text{amb}} - 10^{\circ} \text{ C} \dots + 50^{\circ} \text{ C}$	P-04-311-ATEX	-
P-05	310, 311/2, 320, 510, 511, 520, 530, 533, 534			P-05-310-ATEX	3.060
P-06	310, 311, 320, 510, 511, 520, 530, 533			P-06-310-ATEX	-
P-07	310, 311/2, 320, 510, 511, 520, 530, 533, 534			P-07-310-ATEX	3.080
P-12	310, 311, 320, 510, 511, 520, 534			P-12-310-ATEX	3.100
L-25	310, 311, 320, 510, 520			L-25-310-ATEX	3.020
L-28	310, 311, 320, 510, 511, 520			L-28-310-ATEX	3.040
PI-01	510, 511, 520			PI-01-510-ATEX	-
PI-02	510, 520, 530, 533, 534			PI-02-510-ATEX	-
PI-03	510, 520, 530, 533, 534			PI-03-510-ATEX	-

Other series can be provided on request.

Speed regulation plates for valves acc. to NAMUR

Series	Classification	Operating conditions	Example order number	Catalogue page
MN-063-DR MN-065-DR	II 2G c T5 - 10° C ≤ T _{amb} ≤ 50° C	Compressed air in accordance with ISO 8573-1:2001 Klasse 74- T _{Medium} - 10° C ... + 50° C T _{amb} - 10° C ... + 50° C	MN-063-DR-ATEX	5.026

The following accessories are approved for the valves:

Manifolds:	R-281/n, R-283/n, R-181/n, R-183/n, R-141/n, R-143/n, RF-05, RF-07	Brackets:	R-281-W, R-181-W, R-141-W
Hollow bolt:	H-281, H-283, R-183, H-183, H-143, HI-143, HI-183	Modular manifolds:	RF-09/n, RF-10/n, RF-19-E, RF-09-E1, RF-10-E1, RF-09-E2, RF-10-E2, RF-09-Z1, RF-10-Z1, RF-09-Z1, RF-10-Z1, RF-09-Z4, RF-10-Z4, RF-24, RF-C/n
Blind plates:	R-281-V, R-283-V, R-181-V, R-183-V, RF-09-V, RF-10-V, R-141-V, RF-04-V, RF-C-07-V, R-143-V, MG-07-V	Seal plate:	RF-19-01

Cylinders

Series	Classification	Operating conditions	Example order number	Catalogue page
XL	II 2GD c T4 T 135° C	Compressed air in accordance with ISO 8573-1:2001 Class 74- At V > 1 m/s Class 744 T _{Medium} - 20° C ... + 50° C / T _{amb} - 20° C ... + 60° C Max permissible energy ϕ 32 - 0,1 J, ϕ 40 and 50 - 0,2 J, in the end positions: ϕ 63 - 0,5 J, ϕ 80 - 0,9 J, ϕ 100 - 1,2 J, ϕ 125 - 5 J	XL-040-320-000-ATEX	8.020

The following accessories are approved for the cylinders:

Flexible coupling	FK	Cylinder fixings	XLB- ϕ -01, XLB- ϕ -02, XLB- ϕ -03, XLB- ϕ -04, XLB- ϕ -05, XLB- ϕ -06, XLB- ϕ -07, XLB- ϕ -08, XLB- ϕ -09, XLB- ϕ -10, XLB- ϕ -12
Rod eye	FO and RO up to V _{max} 1 m/s		
Rod clevis	FD and RD		
Piston rod nut	FE and RL		

Rodless cylinders

Series	Classification	Operating conditions	Example order number	Catalogue page
ZX	II 2G T6 T 85° C, - 10° C ≤ T _{amb} ≤ 60° C	Compressed air in accordance with ISO 8573-1:2001 Klasse 74- V _{max} 1 m/s T _{Medium} - 10° C ... + 50° C T _{amb} - 10° C ... + 60° C	ZX-25-S-0500-01ATEX	9.140

The following accessories are approved for the cylinders:

Head mount	ZXB- ϕ -01	Trunnion mount	ZXB- ϕ -10
Head mount tall	ZXB- ϕ -02		

Proximity Sensors

Series	Classification	Order number	Catalogue page
ZS	II 3 GD EEx nA II T4 X IP 67 T 110 °C	ZS-7300 ZS-7301	8.221



Valves from the **MS-18**, **M-05**, **M-07**, **MN-06** and **KN-05** ranges can be provided in explosion proof design in accordance with 94/9/EC (ATEX) for device group II.

For this purpose, special valves are equipped with alternative electrical equipment. The dimensional changes of these components, which are mounted on the valve housing, can be seen on the following pages.

The valves are supplied in an assembled state, complete with valve, as the approval relates both to the electrical and the mechanical components. Individual parts may only be supplied for replacement purposes.

When ordering, the number of the required design must be added to the valve order number, or the required version must be noted in the item text.

Example 1: M-05-510-HN-**Ex037**-24V=

Example 2: M-05-510-HN
Solenoid valve 5/2-way G 1/8,
explosion proof design **Ex037**
Control voltage 24V=.

The specified technical boundary conditions are to enable the user to make a selection. The operating instructions for the valve and the electrical equipment must be taken into account before putting into operation. These are included with each valve and we would be pleased to send them to you on request by quoting Order No. 54-ATEX-01.

Version	Ex037		Ex038
Ignition protection class	Encapsulated with casting compound		Intrinsically safe
Classification	II 2G EEx m IIC T5 II 3D IP 65 T95 °C		II 2G EEx ia IIC T6
Rated voltage	24 V DC	230 V AC	Supply only from certified intrinsically safe circuits with the following maximum values: U ≤ 28 V I ≤ 115 mA P ≤ 1.6 W
Rated current	136 mA	14 mA	
Rated power	3.3 W	3.1 VA	
Cable length	3 m standard		
Medium	Compressed air in accordance with ISO-8573-1 : 2001		
Temperature range	- 10 °C ... + 50 °C (with battery fitted max. + 40 °C)		- 10 °C ... + 50 °C
	Ambient		
	Medium	- 10 °C ... + 50 °C	
Pressure range	min.	Please observe the minimum valve operating pressure.	
	max.	10 bar	8 bar

Order numbers for coils as spare parts

Coils must only be used with the armature tubes provided for the intended purpose.

Item number	Voltage	Cable length	Ignition protection class
23-SP-037-012-03	24 V DC	3 m	Encapsulated with casting compound
23-SP-037-012-05	24 V DC	5 m	Encapsulated with casting compound
23-SP-037-012-10	24 V DC	10 m	Encapsulated with casting compound
23-SP-037-027-03	230 V AC	3 m	Encapsulated with casting compound
23-SP-038-912	24 V DC	-	Intrinsically safe

Dimensional changes compared with standard valves due to Ex-specific components

MS-18 ... Ex037

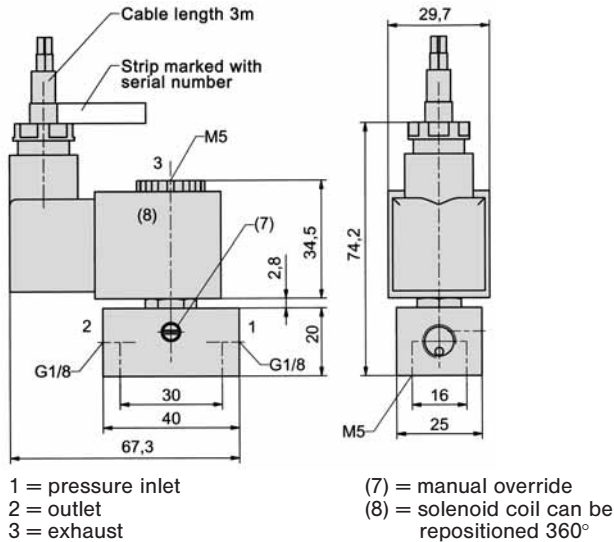

MS-18 ... Ex038

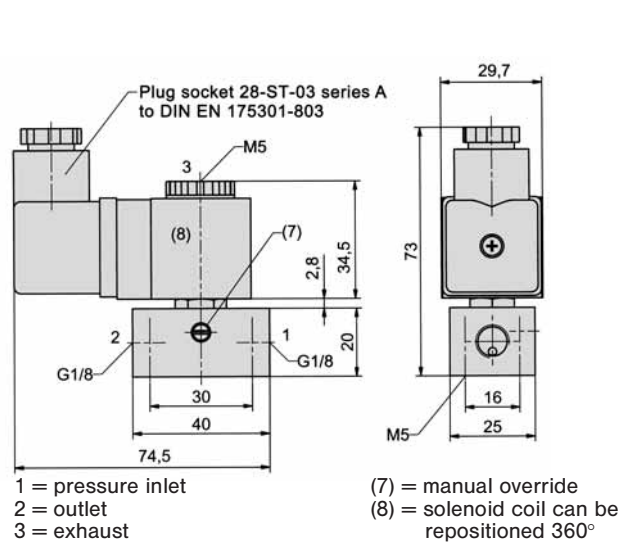

M-05 ... Ex037

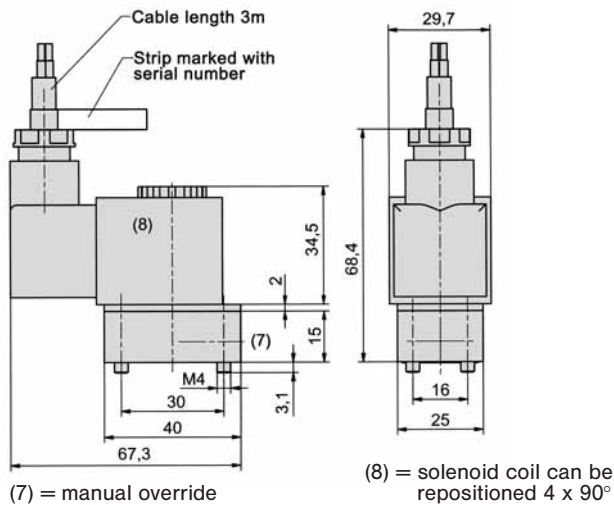

M-05 ... Ex038

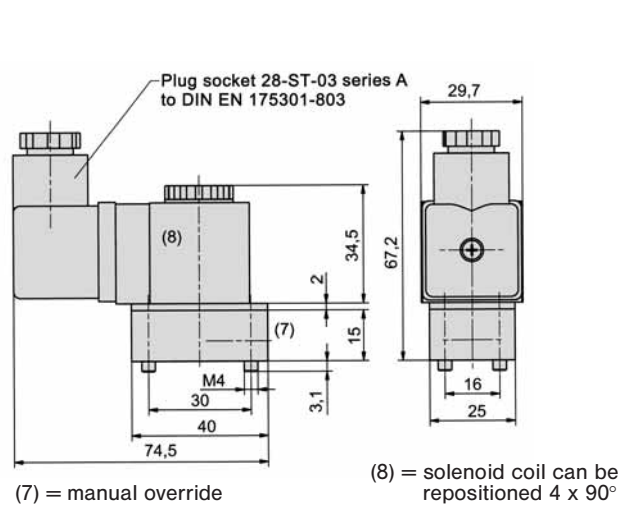

M-07 ... Ex037

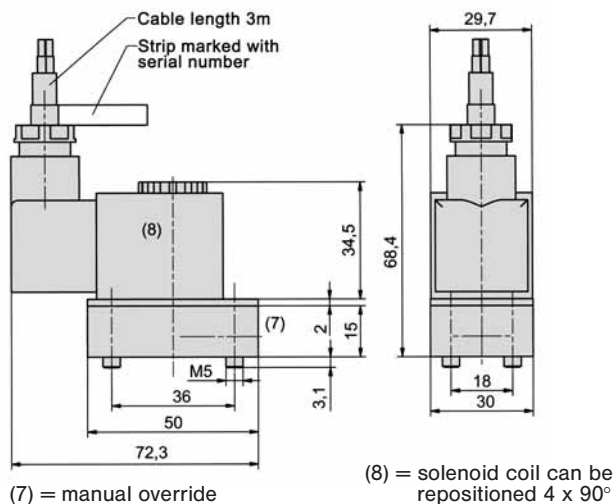

M-07 ... Ex038

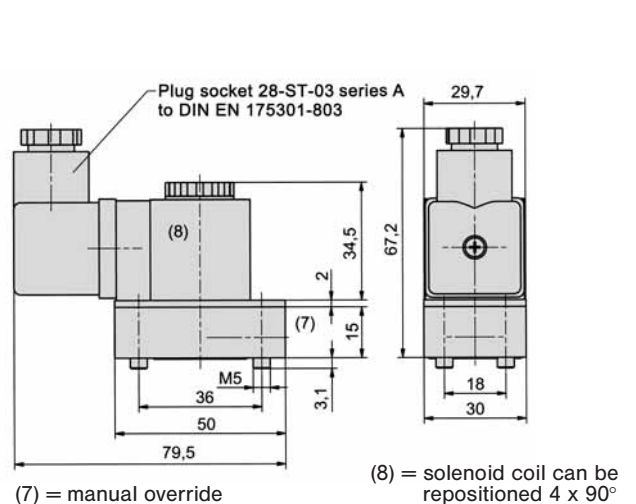

Dimensional changes compared with standard valves due to Ex-specific components

MN-06 ... Ex037

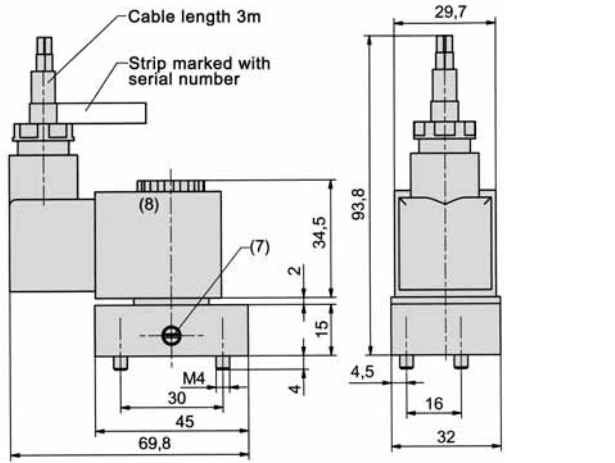

(7) = manual override

(8) = solenoid coil can be repositioned 4 x 90°

MN-06 ... Ex038

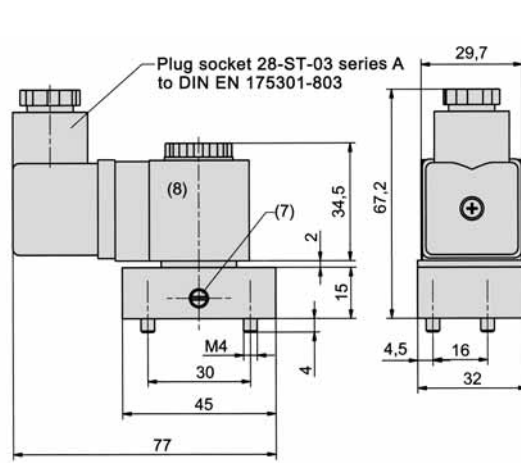

(7) = manual override

(8) = solenoid coil can be repositioned 4 x 90°

M-22 ... Ex037

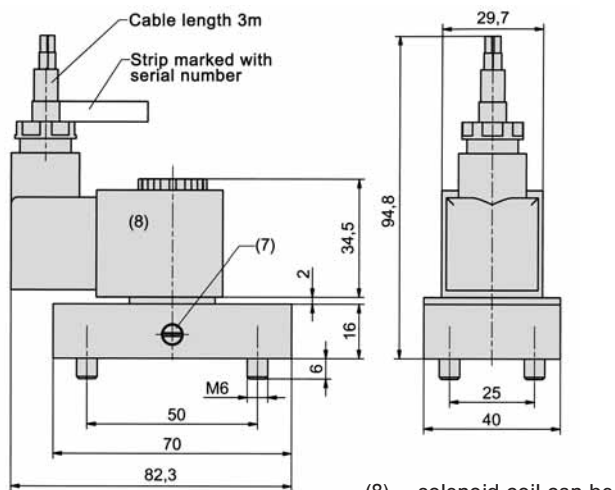

(7) = manual override

(8) = solenoid coil can be repositioned 4 x 90°

M-22 ... Ex038

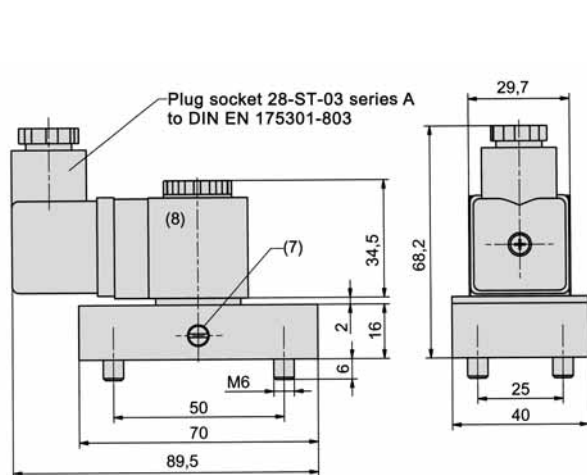

(7) = manual override

(8) = solenoid coil can be repositioned 4 x 90°

KN-05 ... Ex037

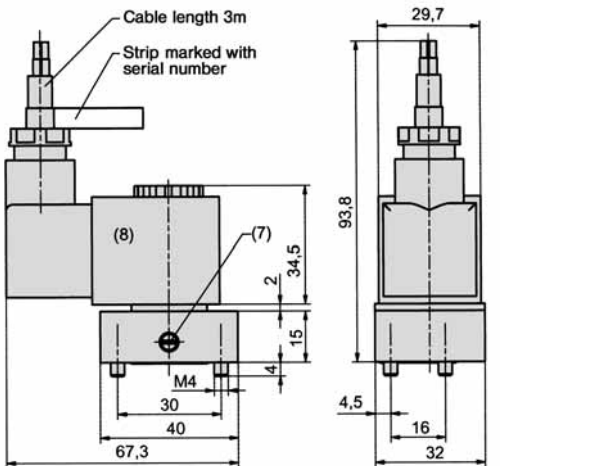

(7) = manual override

(8) = solenoid coil can be repositioned 4 x 90°

KN-05 ... Ex038

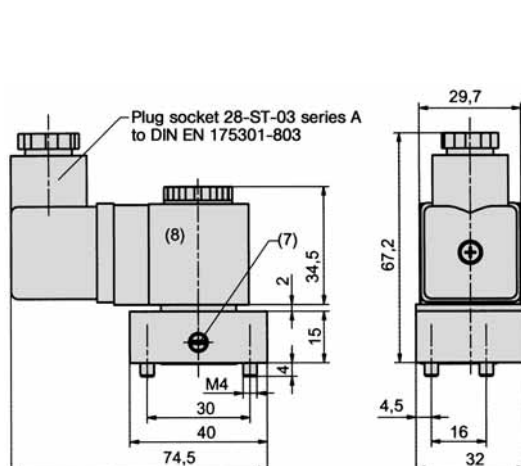

(7) = manual override

(8) = solenoid coil can be repositioned 4 x 90°