

Diese Ventile werden für die automatische Regelung von Dampf, Gas oder Luft eingesetzt. Der Ausgangsdruck kann über Ferneinstellung (Druckveränderung der Vorsteuerluft) reguliert werden.

These valves are designed for control the flow of steam, nitrogen and air. They guarantee highly accurate process control. The output pressure can be varied by means of remote setting (pressure reduction of the pilot control air).

Einbaulage Mounting	Horizontal Horizontal
Betriebsdruck Operating pressure	max. 13 bar (188 psi)
Druckstufe Nominal pressure	PN 40
Leckagerate Leakage rate	ANSI/ FCI 70-2 Class VI
C _v -Wert C _v value	DN 20 2,4 DN 25 3,0
Temperaturbereich Temperature range	max + 205°C (+ 401°F)
Medium Medium	Dampf, Stickstoff, Luft Steam, Nitrogen, Air
Gehäusematerial Body material	Edelstahlguss Stainless steel casting
Material Spindel und Sitz Stem and seat material	Edelstahl Stainless steel
Packungsmaterial Packing material	Kohlegraphitverstärktes Teflon® Graphite-reinforced Teflon®
Dichtungsmaterial Seal type	Kohlegraphitverstärktes Teflon® Graphite-reinforced Teflon®



Bestellschlüssel / Order Code

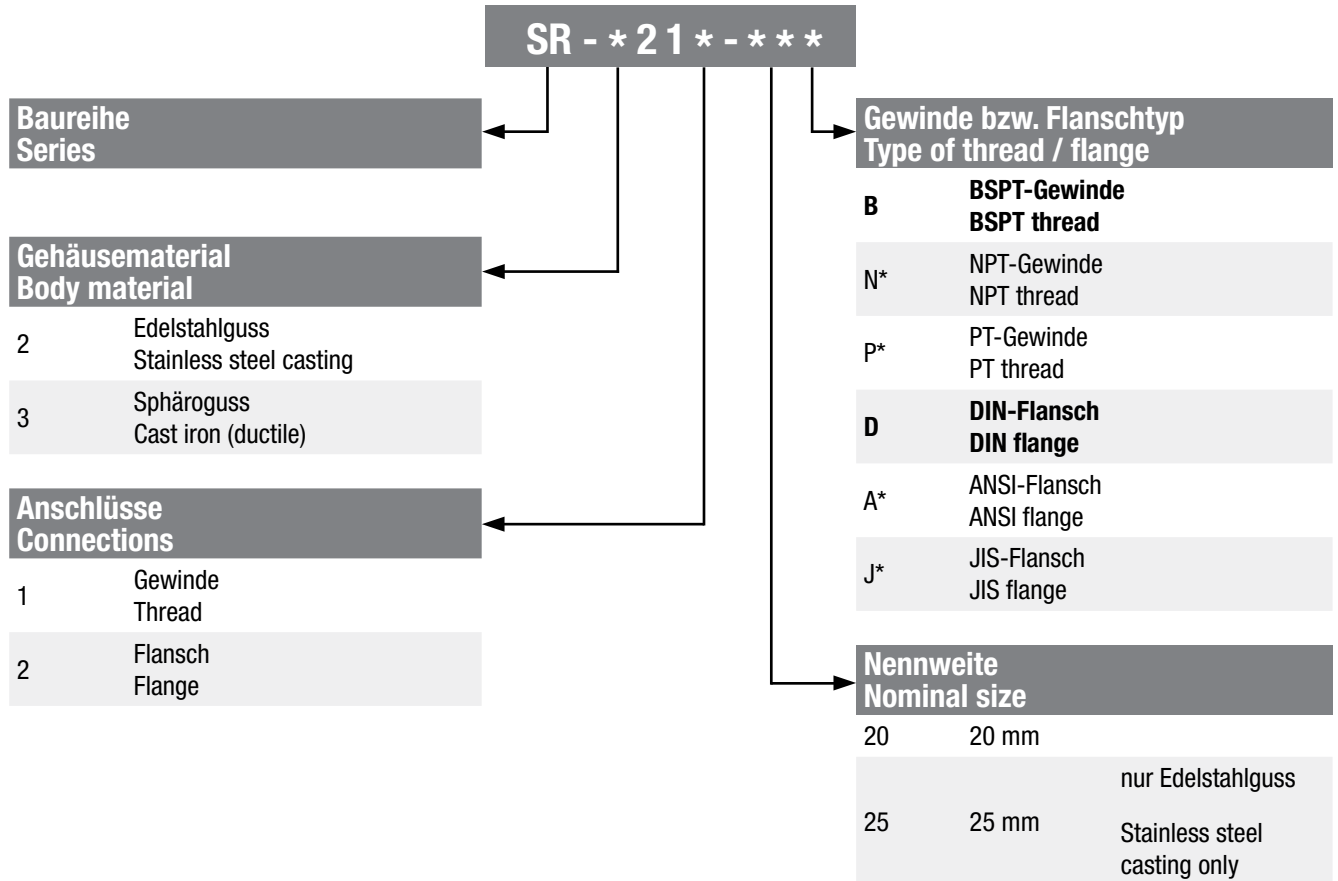

* Verfügbar auf Anfrage. Kein Lagerartikel.

* Available on request. No stock item.

Abmessungen / Dimensions (mm)

Baureihe SR-2 BSPT-Gewinde
 SR-2 series BSPT thread

Baureihe SR-2 NPT- und PT-Gewinde, Baureihe SR-3
 SR-2 series NPT- and PT thread, SR-3 series

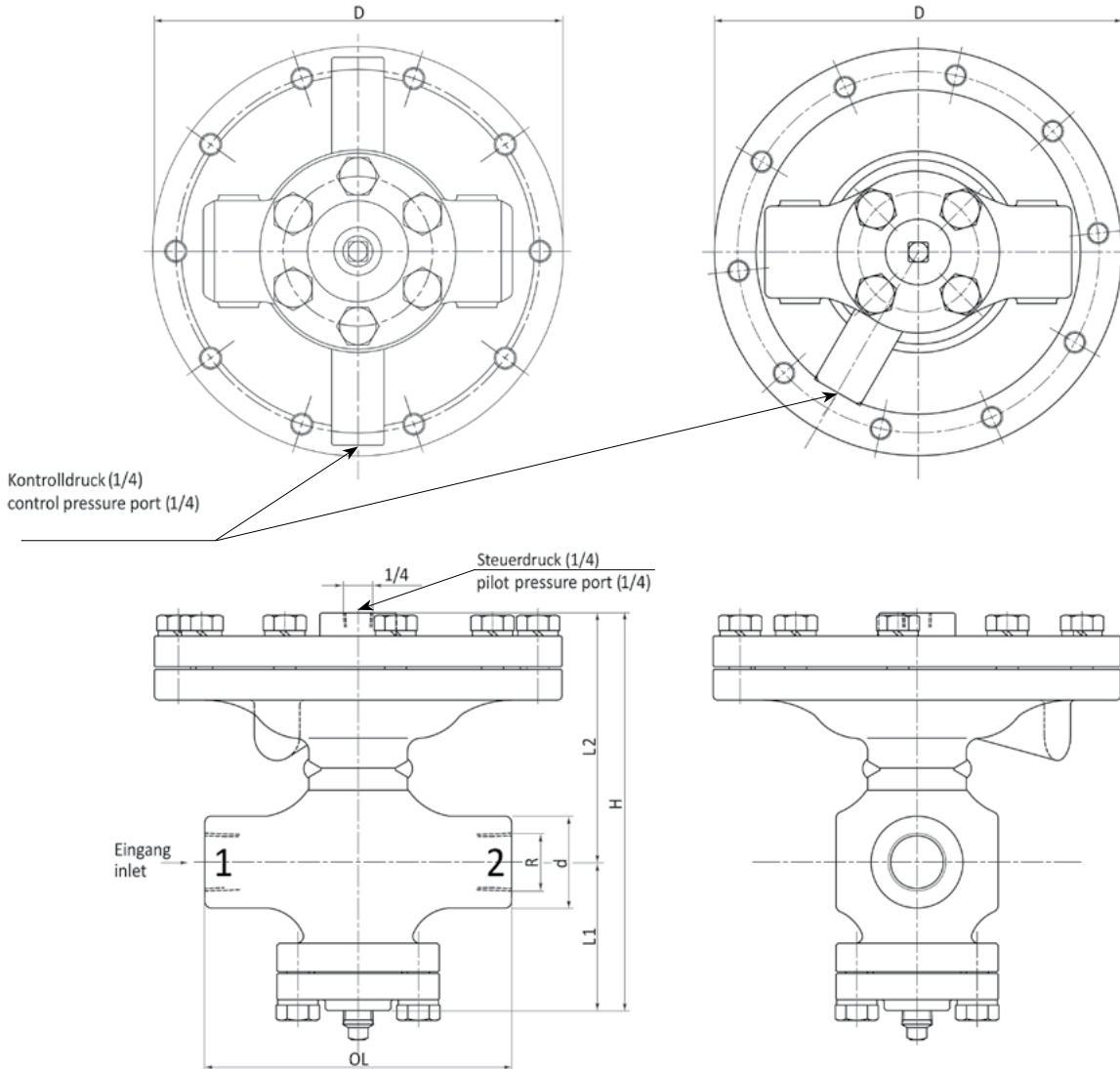

SR Regelventil mit Gewindeanschluss
SR Process regulating valve, tapped

Bestell-Nr. Model No.	DN	Gewindeanschluss R* Internal thread R*	D	d	H	L1	L2	OL	Gewicht (kg) Weight (kg)
SR-2211-20*	20	3/4	186	42	181	68	113	140	8,4
SR-2211-25*	25	1	228	48	205	77	128	165	13,4
SR-3211-20*	20	3/4	186	46	181	68	113	140	8,6

*Innengewinde BSPT (Rc) nach ISO 7-1 DIN EN 10226/1. Ventile mit NPT oder PT Gewinde sind auf Anfrage verfügbar (Die Abmessungen sind identisch zu den Standardventilen mit BSPT Anschlüssen).

Die Bestellnummern sowie die Norm der Gewinde sind dem Bestellcode auf Seite 35 zu entnehmen.

*Thread type BSPT (Rc) according to ISO 7-1 DIN EN 10226/1. Valves with NPT or PT thread are available on request (The dimensions are identical to the standard BSPT version).

For the order number please see the ordering number code on page 35.

Abmessungen / Dimensions (mm)

DIN-Flansch
DIN flange

ANSI-Flansch, JIS-Flansch
ANSI flange, JIS flange

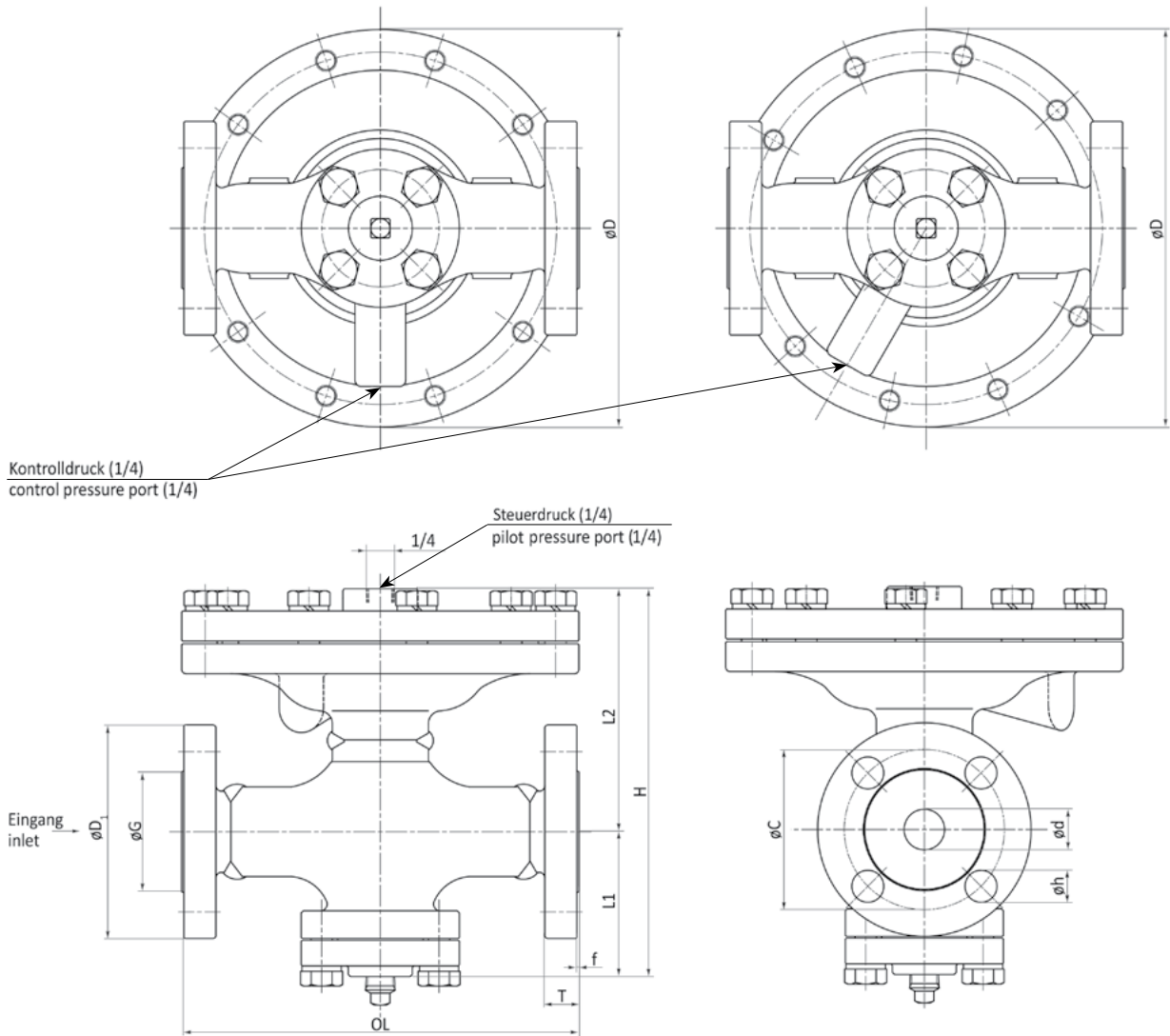

**SR Regelventil mit Flanschanschluss
SR Process regulating valve, with flange**

Bestell-Nr. Model No.	DN	D	H	L1	L2	OL (DIN)	OL (ANSI)	OL (JIS)	Gewicht Weight
SR-2212-20D*	20	186	181	68	113	190	190	186	11,0
SR-2212-25D*	25	228	205	77	128	215	215	212	16,2

**Abmessungen DIN-Flansch
Dimensions for DIN flange**

DN	D ₁	C	G	T	f	N	h	Schraube Bolt
20	105	75	58	18	2	4	14	M12
25	115	85	68	18	2	4	14	M12

* Auch als Version A mit ANSI-Flansch oder J mit JIS-Flansch auf Anfrage verfügbar.
* Also available as version A with ANSI flange or J with JIS flange.

Ersatzteile / Spare parts

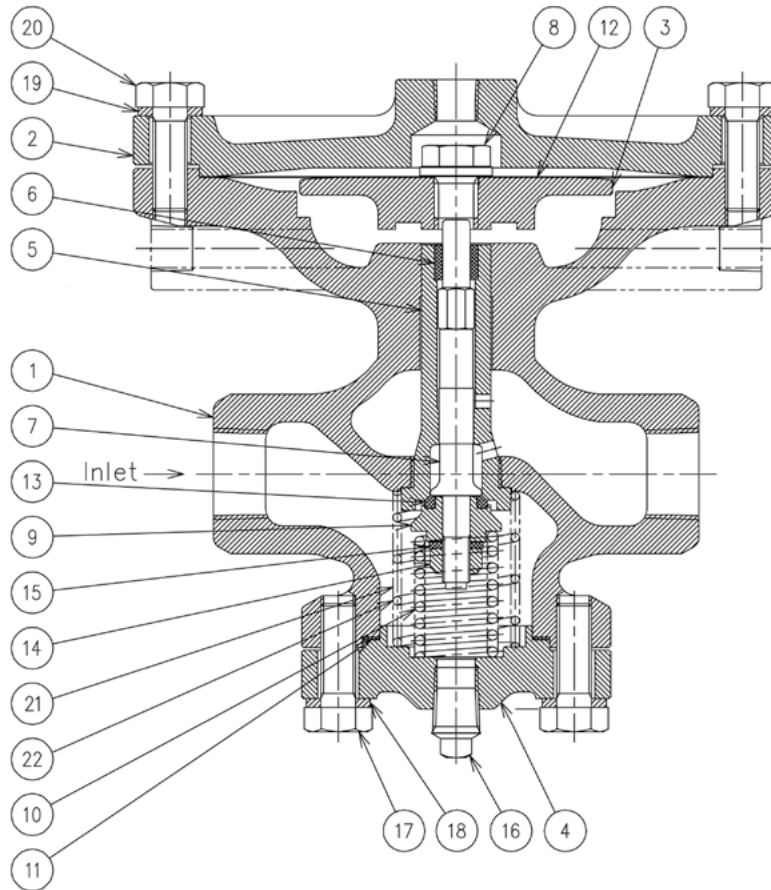

Nr. No.	Bezeichnung Name	Ventil Valve	SR-21120-20*	SR-21125-25*	SR-31120-20*	SR-22120-20D	SR-22125-25D
1	Gehäuse / Body		R-21120-01*	R-21125-01*	R-31120-01*	R-22120-01D	R-22125-01D
2	Membrandeckel / Cover		R-21120-02*	R-21125-02*	R-21120-02*	R-21120-02*	R-21125-02*
3	Membranteller / Diaphragm plate		R-21120-03	R-21125-03	R-21120-03	R-21120-03	R-21125-03
4	Endkappe / Bottom cover		R-21120-04	R-21125-04	R-31120-04	R-21120-04	R-21125-04
5+6	Sitz mit Führungsdichtung / Center seat with guide bushing		R-21120-05	R-21125-05	R-21120-05	R-21120-05	R-21125-05
7	Spindel / Center rod		R-21120-07	R-21125-07	R-21120-07	R-21120-07	R-21125-07
8	Schraube / Screw		R-21120-08	R-21125-08	R-21120-08	R-21120-08	R-21125-08
9	Federzentrierung / Disc adapter		R-21120-09	R-21125-09	R-21120-09	R-21120-09	R-21125-09
10	Feder / Disc spring		R-21120-10	R-21125-10	R-21120-10	R-21120-10	R-21125-10
11	Dichtung / Gasket		R-21120-11	R-21125-11	C-21132-30	R-21120-11	R-21125-11
12	Stahlmembrane / Diaphragm (2)		R-21120-12	R-21125-12	R-21120-12	R-21120-12	R-21125-12
12-1	Stahlmembrane / Diaphragm SUS631 (2)		R21120-12Z03	R21125-12Z03	R21120-12Z03	R21120-12Z03	R21125-12Z03
13	Sitzring / Disc ring		C-21120-28	C-21125-28	C-21120-28	C-21120-28	C-21125-28
14	Mutter / U-Nut		C-21120-06	C-21125-06	C-21120-06	C-21120-06	C-21125-06
15	Federring / Spring washer		R-21120-15	R-21125-15	R-21120-15	R-21120-15	R-21125-15
16	Stopfen / Plug		R-21120-16	R-21125-16	R-21120-16	R-21120-16	R-21125-16
17	Sechskantschraube / Hex head screw		R-21120-17 (4)	R-21125-17 (4)	R-31120-17 (6)	R-21120-17 (4)	R-21125-17 (4)
18	Federring / Spring washer		R-21120-18 (4)	R-21125-18 (4)	R-21120-18 (6)	R-21120-18 (4)	R-21125-18 (4)
19	Federring / Spring washer (10)		R-21120-19	R-21125-19	R-21120-19	R-21120-19	R-21125-19
20	Sechskantschraube / Hex head screw (10)		R-21120-20	R-21125-20	R-21120-20	R-21120-20	R-21125-20
21	Filter / Filter		-	-	R-31120-21	-	-
22	Filterfeder / Filter spring		-	-	R-31120-22	-	-

* bitte ergänzen: B = BSPT-Gewinde, N = NPT-Gewinde / * please complete: B = BSPT thread, N = NPT thread

Verhältnis zwischen Steuerdruck und Ausgangsdruck
Ratio between pilot pressure and output pressure

